



## ► Q-Siren® | Siren

### FEATURES

- The sound of the Q-Siren is a registered trademark of Federal Signal Corporation
- The distinct sound provides recognizable long distance warning
- Utilizes a unique clutch design that provides a longer coast down sound while reducing the amp draw
- Beautifully streamlined and polished electro mechanical siren produces 123 decibel at 10-feet
- Three-year warranty

#### **An iconic fire truck siren**

It's not a fire truck unless it's got a Q-Siren®. With more than 50 years of fire service tradition and history, the Federal Signal Q-Siren® (model Q2B®) is a beautifully streamlined, chrome-plated siren designed to provide unparalleled reliability for long-life operation. When mounted on a fire truck, the Q-Siren delivers powerful warning sound, more than any other electromechanical siren.

#### **Longer coast-down sound**

A heavy-duty coaster clutch is standard on Q2B models. The unique coaster clutch design enables the siren to deliver longer coast-down sound once power is removed to reduce battery drain. The "worry free" clutch is subject to very little wear and requires no service attention or adjustments. Use the standard electric brake to quickly silence the siren.

#### **Pedestal or recessed mounting**

The Q-Siren is available in two Q2B models. The Q2B-P comes with a pedestal for bumper mounting and the Q2B-NN is designed for recessed mounting in the bumper. Both models are a compliment to the fire truck's polished chrome bumper finish.

For flat and curved apparatus bumpers, a special bracket, the Q-MT is available. This rugged, durable mount is easy to install. Constructed of tough 3/8-inch steel, the Q-MT design protects the siren from the impact of rough roads



#### **Hands-free operation**

For increased convenience, the Q2FSK foot switch kit is also available. The kit comes with everything necessary to wire a footswitch to any Q2B model enabling the operator to power the siren "hands-free."

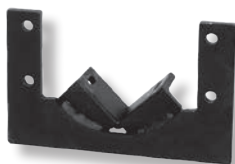

The Q-MT mount is designed for flat or curved bumpers on fire apparatus.

The distinctive sound of the Q2B electro-mechanical siren is a registered trademark owned by Federal Signal Corporation.

**Specify model**

- Q2B-012NNSD      Q2B, mechanical siren, Chrome, recess mount
- Q2B-012PSD      Q2B, mechanical siren, Chrome, pedestal mount

**Specify accessories (optional)**

- Q-MT      Kit, Q2B, bracket for recess mounting Q2B siren
- Q2FSK    Kit, Q2B, foot switch

**Specifications**

Voltage	12 VDC
Operating Current	100A
Sound Output	123 dB @ 10ft.

**Physical Specifications**

Height	10.5 in (26.7 cm)
Length	14.0 in (35.6 cm)
Diameter	10.0 in (25.4 cm)

**Ship Weight**

49.0 lbs (23.0 kg)

**MOUNTING DIAGRAM FOR PEDESTAL MOUNT**

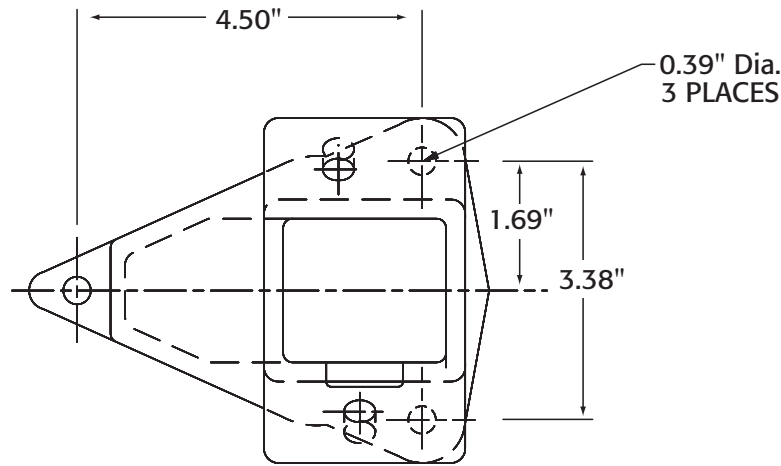

**BUMPER CUTOUT FOR Q-SIREN (Q-MT)**

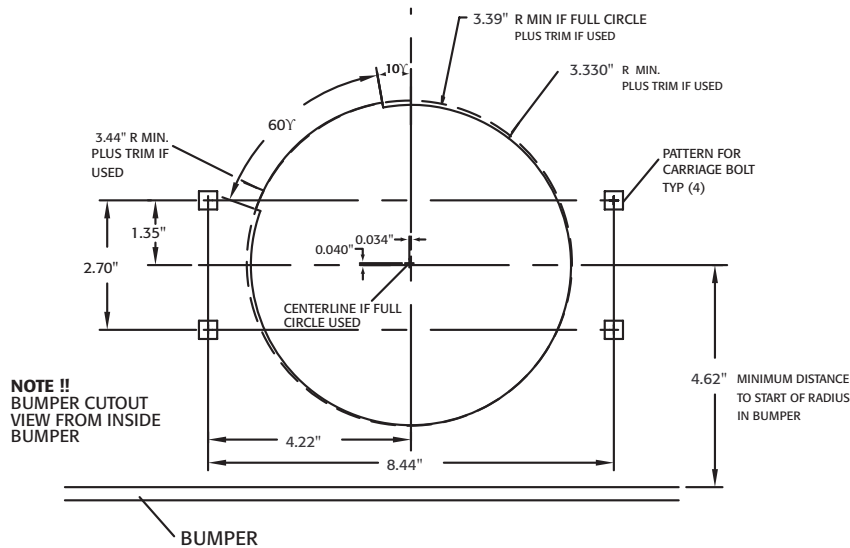

Warning: Sirens and Speakers may produce LOUD sounds necessary to request the right-of-way. Sirens and Speakers may cause hearing damage. Wear hearing protection.

Q-Siren and Q2B are trademarks of Federal Signal Corporation. The distinctive sound of the Q2B electro-mechanical siren is a registered trademark owned by Federal Signal Corporation.

